



July 2011

Sectional Cold Water Storage Tank

Installation & Maintenance Instructions



Ballyspillane Ind. Est, Killarney, Co. Kerry, Ireland.
Tel: +353 (0)64-6632421 • Fax: +353 (0)64-6632777
Email sales @ killarneyplastics.com
Web www . killarneyplastics.com
www . kmgroup.eu



Customer : _____

ST17C – August 2009

Project Reference : _____

Tank Size : External Dimensions : _____ x _____ x _____ mm

Nominal Capacity : _____ litres.
_____ gallons.

Tank Type : Light Duty Cover
Heavy Cover
Heavy Cover and Insulated to Format 30
Other _____

Internal Under Water Bolts : Galvanised Mild Steel
Stainless Steel *

* We recommend that S/S bolts be used on the base of all tanks.

External Bolts : Galvanised Mild Steel
Stainless Steel

Internal Under Water Stay System : Stainless Steel

Optional Extras :

- Externally Flanged Base
- Internally Flanged Base
- Ball Valve Housing
- Across Tank Divider
- Along Tank Divider
- Internal Ladder
- External Ladder
- All Half Panels
- Insulated Base
- Condensation Tray

Tank Configuration :

Multiples of 1x1 meter plus ½ & ¼ panels as necessary (Metric)

Multiples of 1.22 x 1.22 meter (4x4 ft) plus ½ & ¼ panels as necessary (Imperial)

Tank Serial No. : _____

Approximate Delivery Date : _____

Other Information : _____

Index

	Page
1. Guide Lines on Locating tanks	4
2. Guide Lines for different models of tanks	5
3. Data Sheets	
i Insulated Tanks	6
ii Vents & Overflows	7
iii Condensation Trays	8
iv Ball Valve Housings	9
v Connections	10
4. Base Details	
Metric Tanks	12
Imperial Tanks	13
5. Maintenance Procedures	14
6. Glossary of terms	15
7. Killarney Plastics Contract Conditions	16
8. Sample Tank Maintenance Log Book	17

Note :

- Guarantees are only valid if tanks are installed and maintained strictly in accordance with the following instructions.
- Copies of Maintenance and Installation instructions should be passed on to the end user.
- The end user should ensure that tanks are maintained in accordance with BS 6700.
- Guarantees are only valid if appropriate overflows are fitted, failure to fit overflows can lead to tanks operating at greater pressures than they are designed for.

Guidelines for Locating Water Tanks

General

The following recommendations are generally for elevated tanks, as tanks at elevated positions can cause serious damage to the surrounding area in the event of wall, pipe or structural support failure resulting in water spilling out at a fast rate. Consideration must be given to minimise the effects of such an occurrence, in terms of the positioning of the tank and regular inspection for defects.

- Water tanks should be located so as to prevent water damage or consequential loss in the event of leakage howsoever occurring.
- All tanks which are located above water sensitive areas should have a bund wall around them with adequate evacuation ducts.
- All other tanks should have Condensation or Drip trays to prevent nuisance damage and to keep floors dry.

Over the years we have seen tanks fail due to age, lack of maintenance, failure of the structural supports underneath the tanks, contaminated water attacking the internal fittings, ball valve failure where overflows were not fitted, vandalism etc.

Handrails on Tank Roofs - Health & Safety Requirements

Handrails may be necessary to satisfy Health & Safety Regulations. The type of railing required is dependant on the tank height, distance from ground level, access etc. Please confirm which handrail arrangement is required so that we can make the necessary inclusion. Killarney Plastics can supply and install ladders and railings but we must be informed of the exact details prior to quoting the job. We assume that the end user is making his own arrangements unless we are informed otherwise.

Water Tanks on top of Buildings

Water tanks located on top of any building should be sited at least 1.2 meters away from the edge of the building.

It would be preferable if the water tank was sited 1.5 times the height of the tank away from the edge of the building. In the event of failure, this would allow the water to spread itself over a much wider area before spilling over the edge of the building and possibly taking personnel or debris with it.

Water Tanks on Elevated Structures

For water tanks located on top of elevated structures, a walkway of at least 1 meter should be provided all round the water tank to allow for maintenance and inspection. This walkway should comply with health and safety regulations.

Potable Water Tanks

To comply with the Health & Safety Executive regulations on the Control of Legionellosis 1998, Cold Water Storage Tanks must be located in areas that are "*readily accessible for cleaning*". Regular Maintenance and Inspections as required by Health & Safety Legislation.

Guidelines for different models of tanks

Standard Tank : This tank is complete with internally flanged base, externally flanged side walls. All under water stays are Stainless Steel and all bolts are Galvanised to BS 729.

Light Duty Cover : Only suitable for indoor use, and for the storage of foul water. They are not designed to take Man weight.

Heavy Duty Cover : Suitable for Indoor and Outdoor Use, and for the storage of foul water. These tanks have internally flanged lid panels, similar to those used in the base.

Heavy Duty Cover and Finished to Format 30 : Suitable for Indoor, Outdoor use and for the storage of Drinking Water, as defined in our specification Killarney Plastics Format 30 on page 5.

Note :

- To comply with current legislation all tanks that store water that may be used for drinking must be protected, they must meet the requirements set out in the water byelaws
- BS 6700 states that because any cold water tap is likely to be used to drink from, all such taps not directly connected to the mains shall be supplied only from tanks that are protected.
- Where drinking water has been stored in an inadequately protected tank, a water analysis should be considered and adequate protection installed.
- Tanks of over 1000 litres (220 gallons) shall be divided or have standby tanks to facilitate repairs and maintenance. It should also have a wash out pipe or drain out taps, these to terminate above an outside gully to prevent wastage.
- Tank insulation materials should not suffer permanent structural damage from contact with water generally Phenolic and Polyurethane closed cell foams comply. Where pipe cut outs go through insulation panels, bessels should be fitted to protect the exposed insulation from the ingress of moisture, insects and vermin and preserve the integrity of the insulation with a protective finish.

Types of Bolts : Standard Tanks come complete with Bolts galvanised to BS 729, we recommend that Consultants specify Stainless Steel grade 316 S16 bolts under water.

Dividers : In any situation where there is only one water storage tank in a building and the capacity is greater than 1000 litres (220 gallons), BS 6700 states *“To avoid interruption of the water supply when carrying out repairs or maintenance, the cistern shall be provided with compartments or standby cistern”*. Where drinking water is being stored, two separate tanks are recommended as it is difficult to detect cross contamination from one side of a division wall to another.

Condensation Trays : They should be used in any instance where condensation, drips from pipe work, or from the tank could cause nuisance damage or render floors wet and slippery.

Ball Valve Housing : Enclosed chamber containing an access hatch above the level of the cover, permitting the level control mechanism to be mounted at a higher level than would otherwise be possible. The overflow(s) must be placed on the tank side wall and not on the Ball Valve Housing. Water must be kept below tank roof level. Ball Valve Housings are only necessary where very large ball valves are used.

Ladders : Where tank depth is 1.5 m or greater, internal and external ladders should be specified. If the tank is on a raised platform then ladders may be required on tanks lower than this height.

Externally Flanged Base : (Reverse base) These types of tanks allow the tank to be totally drained down, as the base is flat, they also allow access to all the bolts from outside the tank. 450 mm clearance is required underneath the tank for access to the base bolts.

Tanks Insulated and finished to Format 30

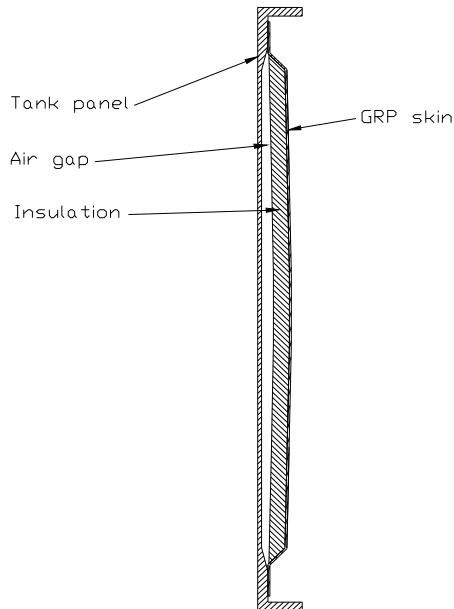

Note : This is only an example of one type of insulation skin, there are different arrangements for different types of tanks.

- Current legislation states that water hot or cold, in any premises that might be used for human consumption must be of potable quality.
- In addition to tank material specifications, there are now further requirements for lid design, the screening of vents, breathers, overflows, warning tell tale pipes and the provision of insulation which will help prevent freezing and also help keep water as cool as practicable, ideally less than 20°C.
- Format 30 is Killarney Plastics description of tanks with Heavy Duty panel covers, complete with screened vents, overflows, warning pipes etc and having side wall and roof panels with a (u) value of 2.5 w/m²K, (tanks under 1m high have a slightly higher value). This value meets the requirements of section 30 of the water bye laws in the majority of situations. Tanks in boiler rooms etc may also need base insulation. The purchaser can specify extra requirements or thermal transmittance after considering the period of protection necessary, the tank location and the surrounding conditions.

Please Note : Insulation slows down but does not prevent heat loss or gain over protracted periods. Additional information is available in BS 7491 & BS 6700.



5150 x 4150 x 2000 mm 40,000 Litre (8,800 Gallons) Water Tank, Insulated to Format 30

Format 30 Fittings

Screened Air Inlet Vent.

There are different types of air vents available. One of these is to be fitted to the lid in every Heavy Cover and Format 30 Tank, the hole for the vent will be pre-drilled in the lid panel. Larger tanks may require more than one vent. Tanks with dividers to roof will require two number vents.

Note : During commissioning the air inlet vent should be checked to ensure that it is attached correctly to the tank.

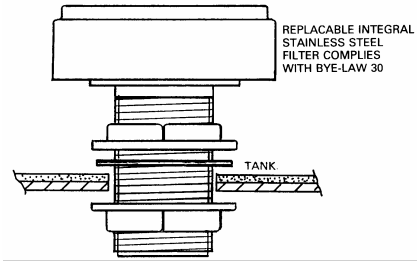

Screened Overflow

A 2" screened overflow is supplied with each Format 30 Tank. Please contact us if a different size is required. These are not fitted by Killarney Plastics.

Overflows larger than 1 1/2 " have a different configuration.

Warning or tell tale pipes if specified must also be screened.

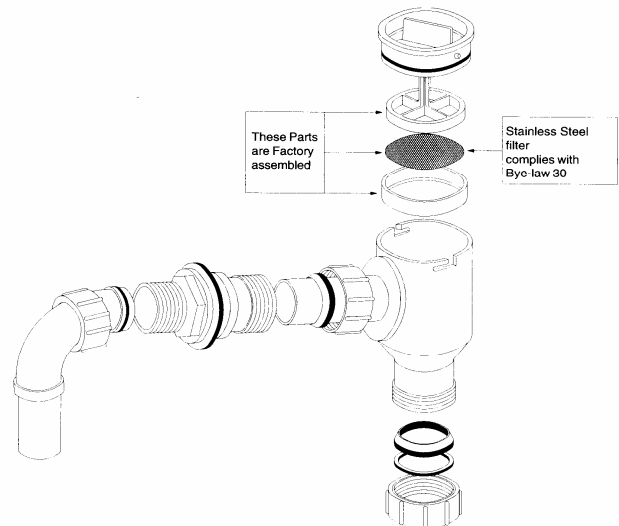

Bye Law 30 fittings.

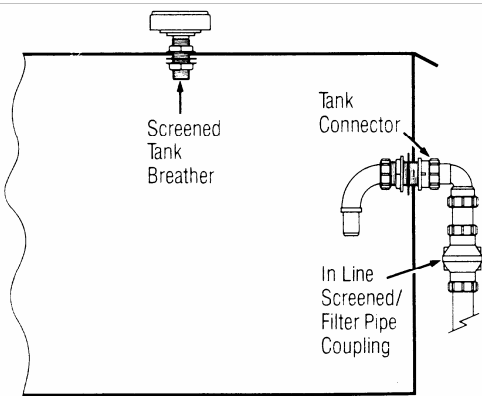

Condensation Trays

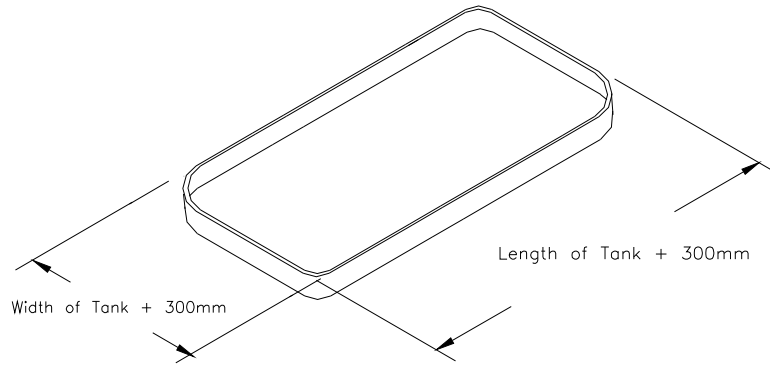

Killarney Plastics manufacture condensation trays to suit all sizes of Water Storage Tanks. For Sectional cold water storage tanks, the tray extends round the tank by 150 mm. i.e. a sectional tank with internal dimensions 4000 x 3000 mm will have a tray approximately 4300 x 3300 x 75 mm high.

Trays for large sectional tanks are joined on site.

Condensation Trays should be used in any instance where condensation, drips from pipe work or from the tank could cause nuisance damage or render floors wet and slippery.

Condensation trays should be water tested at time of testing tank.

A condensation tray is not a substitute for a bund wall or for tanking out a room.

APPROPRIATE OVERFLOWS MUST BE FITTED AS CLOSE AS POSSIBLE TO THE BASE OF THE TRAY. THESE MUST BE FITTED BEFORE THE TANK IS FILLED.

BALL VALVE HOUSING

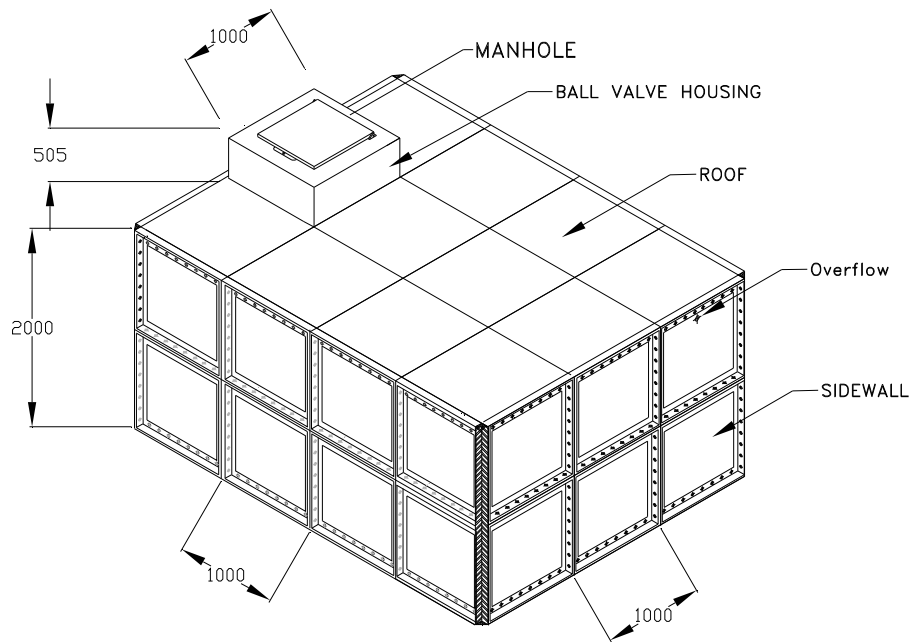

All dimensions are in mm

Isometric view of a Ball Valve Housing on a 4000 x 3000 x 2000 mm Sectional cold water storage tank.

A Ball Valve Housing is an enclosed chamber containing an access hatch above the level of the cover, which leaves space for larger ball floats to raise up and shut off the water supply.

Specification

External Dimensions : 1000 x 1000 x 505 mm high

Space required : 1000 mm clearance space is required above the roof of the tank,
i.e. For a 2m high tank the room needs to be 3000 mm high.

Note : The overflow(s) must be placed on the tank side wall and not on the Ball Valve Housing. Water must be kept below tank roof level.

Pipe Connections for Cold Water Storage Tanks.

- If the tank is to be drained down at a fast rate or by pumps etc, Killarney Plastics should be contacted so that adequate vents can be placed on the tank. The standard vent is 2”.
- Connections of 100mm (4”) nominal bore or over require studded flange pads to suit BS 1962, table D&E flanges for pipework connections.
- Connections below 100mm (4”) nominal bore may be made by cutting holes in situ. First determine whether single or double sided connections are required and cut hole in panel to suit external pipe diameter.
- For connections over 50 mm (2”) nominal bore use two flanges screwed BS21 taper thread, drilled to BS 10. Offer one flange to panel concentric with hole and transfer drill bolt holes into panel. Set one flange to external pipe and using appropriate gaskets, assemble external flanged pipe using other flange as an internal backing plate. Finally bolt up.
- For double sided connections proceed as above, replacing internal flange with the required fitting, e.g. ball valve, strainer basket etc.
- For connections of 50 mm (2”) nominal bore or less proceed as above or alternatively use threaded flanges or backnuts (with rubber gaskets) on standard longscrew to BS 1387.

The figures below show hole diameter for in situ pipe fittings and minimum dimensions for the location of connections from panel edges.

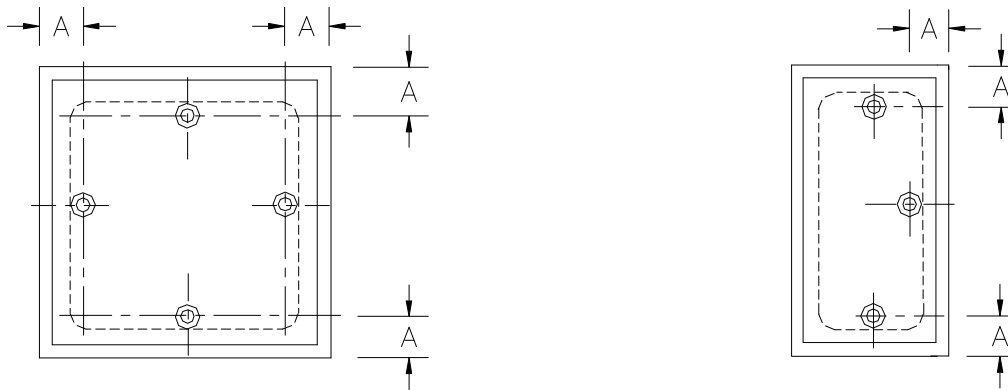

Nominal Bore Diameter	Nominal Hole Size	Dimension A
12.7 (1/2)	22 (7/8)	158 (6 1/4)
19 (3/4)	28 (1 3/32)	161 (6 3/8)
25.4 (1)	35 (1 3/8)	167 (6 5/8)
31.7 (1 1/4)	44 (1 31/32)	170 (6 3/4)
38.1 (1 1/2)	50 (1 31/32)	177 (7)
50.8 (2)	61 (2 13/32)	186 (7 3/8)
63.5 (2 1/2)	78 (3 1/16)	193 (7 5/8)
76.2 (3)	90 (3 9/16)	202 (8)
89 (3 1/2)	105 (4 1/8)	212 (8 3/8)

millimetres/inches

General Notes

All pipe work must be self supporting. If welded or brazed-on flanges are used, all heat must be dissipated before connections are made to the tank. Holes may be cut with normal metal working tools.

Note: These figures only apply to Uninsulated Tanks

Pipe Connections for Insulated Cold Water Storage Tanks.

The areas where pipe connections can be made on insulated tanks are more restricted than in standard tanks, the picture below shows a recess in the insulation panel to allow for the pipe connection. Standard insulated tanks come with three insulation panels with recesses. More can be supplied if required.

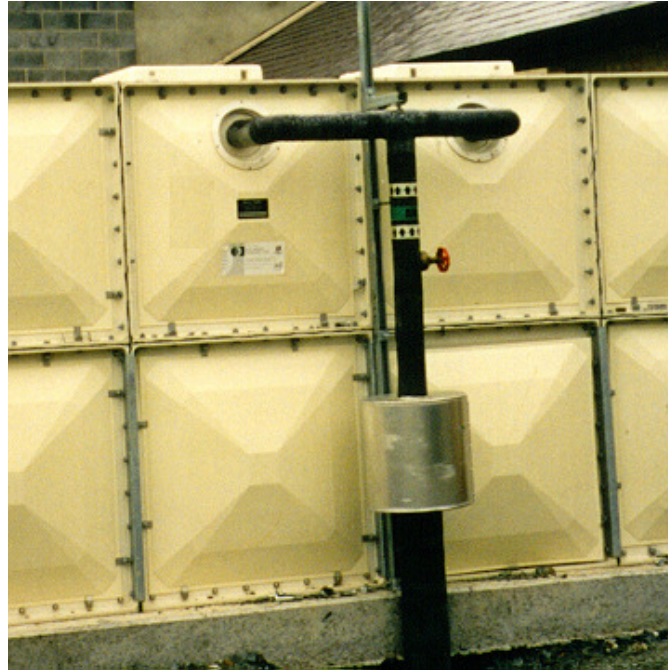

The recesses have a diameter of 180 mm, they are located centrally on the vertical axis, the centre of the recess is 205 mm from the edge of the panel on Metric tanks and [170 mm from the edge of the panel on Imperial tanks](#).

The recesses have the same dimensions on half panels.

Recesses for connections can be made in different locations but Killarney Plastics must be notified of this prior to order.

General Base Details /Design Considerations (METRIC)

Tanks based on 1x1 & 1x.5 m panels

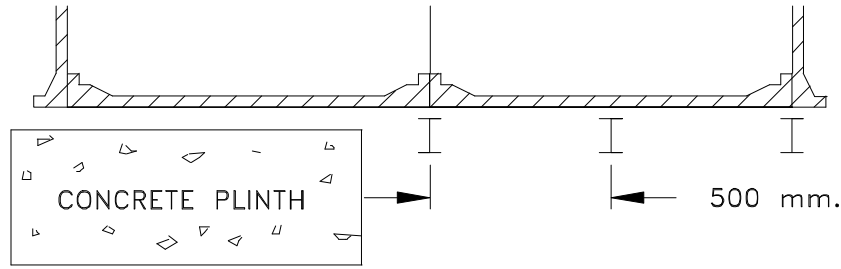

Standard base tanks (internally flanged base panels) may be laid directly on a concrete plinth having a trowelled finish, brushed clean and free from any local protuberances. It should be flat, level and not vary more than 6 mm in any 6 m, measured laterally or diagonally with a maximum variance of 2 mm per metre. The plinth must exceed the nominal tank dimensions by a minimum of 175 mm.

Tanks erected on elevated structures (RSJ beams or brick courses in one direction only). Bearers must be at 500 mm centres. Bearer length must exceed nominal tank dimensions by a minimum of 150 mm plus any extra for fixings. All bearer walls to be flat and level. For bearer width see chart below.

Typical Tank Room (Plan)

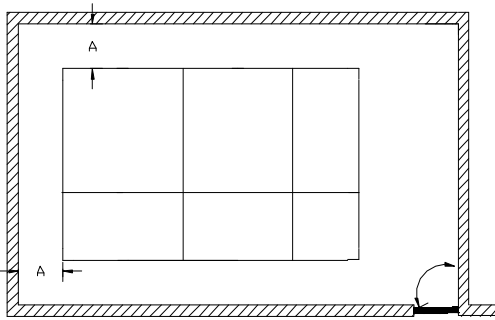

For dimension 'A' see chart below. This clearance should be on all sides of the tank, also a top clearance of 650 mm is required for standard access hatch to open. (This can be reduced to 450 mm provided that Killarney Plastics is notified prior to dispatch). If the tank has to be pushed closer to any wall after assembly or if the working space is reduced (dimension 'A') at a later stage, by the building of walls etc, responsibility will rest with others.

Example : Tank where base is 2650 x 1650 mm

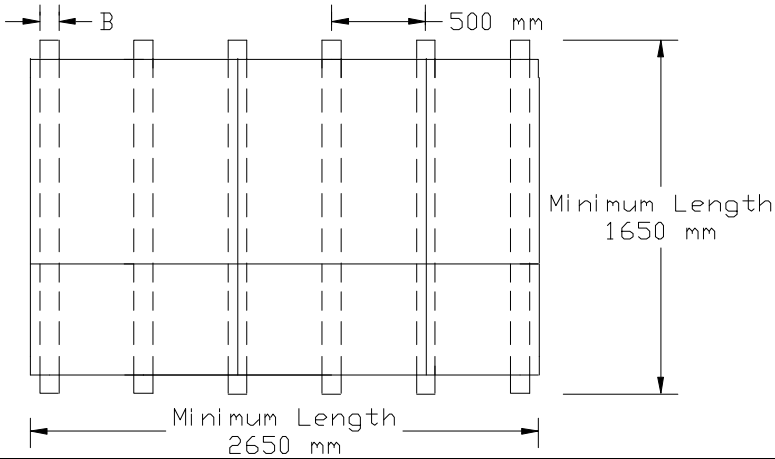

General Notes:

1. Tanks should not be placed above / beside water sensitive areas, unless there is adequate bunding.
2. Client to design suitable bearers to suit load conditions. Water load = $1000 \text{ kg/M}^3 + 20\%$ for tank.
3. Bearers can run in either direction.
4. It is necessary that the top of each bearer be flat, level and level with it's neighbouring bearers.
5. Deflection must not exceed $1/500^{\text{th}}$ of the unsupported span of the bearers. The unsupported span can only be in one direction.
6. Adequate overflows should be fitted to prevent the tank from being pressurised.
7. Tanks in exposed places may be susceptible to movement in high winds, especially when empty. These may need to be anchored to the base, this work is to be carried out by others.

Working Space and Bearer Width

Tank Height	Dimension 'A'	Bearer Width 'B'
Mm	Mm	m
500	450	75
1000	450	100
1500	500	100
2000	600	150
2500	650	150
3000	700	150

Please Contact us for Tank Specific Base Details

General Base Details /Design Considerations (IMPERIAL)

Tanks based on 1.22m x 1.22m & 1.22m x.61m panels

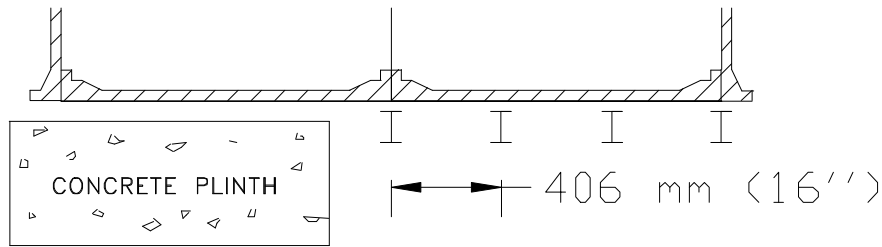

Standard base tanks (internally flanged base panels) may be laid directly on a concrete plinth having a trowelled finish, brushed clean and free from any local protuberances. It should be flat, level and not vary more than 6 mm in any 6 m, measured laterally or diagonally with a maximum variance of 2 mm per metre. The plinth must exceed the nominal tank dimensions by a minimum of 175 mm.

Tanks erected on elevated structures (RSJ beams or brick courses in one direction only). Bearers must be at 406 mm (16'') centres. Where a half panel is used one bearer at 610 mm (24'') centres is required. Bearer length must exceed nominal tank dimensions by a minimum of 150 mm plus any extra for fixings. All bearer walls to be flat and level. For bearer width see chart below.

Typical Tank Room (Plan)

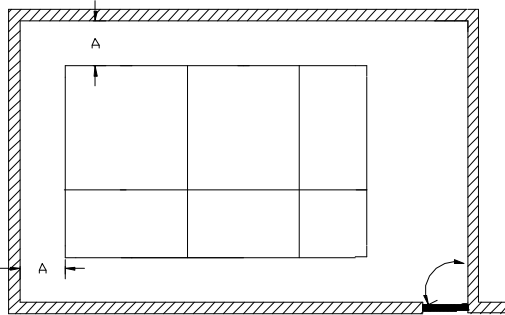

For dimension 'A' see chart below. This clearance should be on all sides of the tank, also a top clearance of 650 mm is required for standard access hatch to open. (This can be reduced to 450 mm provided that Killarney Plastics is notified prior to dispatch). If the tank has to be pushed closer to any wall after assembly or if the working space is reduced (dimension 'A') at a later stage, by the building of walls etc, responsibility will rest with others.

Example : Tank base is 3200 x 1980 mm (10'6" x 6'6")

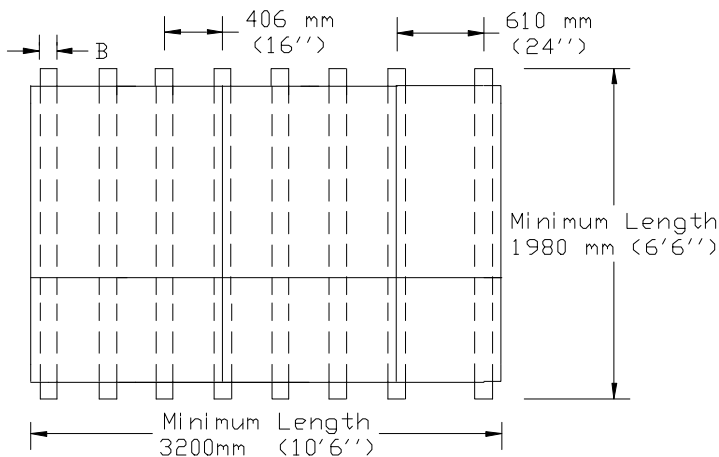

General Notes:

1. Tanks should not be placed above / beside water sensitive areas, unless there is adequate bunding.
2. Client to design suitable bearers to suit load conditions. Water load = $1000 \text{ kg/M}^3 + 20\%$ for tank.
3. Bearers can run in either direction.
4. It is necessary that the top of each bearer be flat, level and level with it's neighbouring bearers.
5. Deflection must not exceed $1/500^{\text{th}}$ of the unsupported span of the bearers. The unsupported span can only be in one direction.
6. Adequate overflows should be fitted to prevent the tank from being pressurised.
7. Tanks in exposed places may be susceptible to movement in high winds, especially when empty. These may need to be anchored to the base, this work is to be carried out by others.

Working Space and Bearer Width

Tank Height	Dimension 'A'	Bearer Width 'B'
Mm	mm	Mm
610	450	75
1220	450	75
1830	500	75
2440	600	150

Please Contact us for Tank Specific Base Details

Maintenance Recommendations for Sectional Water Storage Tanks

Water Tank Temperature Maintenance Interval: 6 monthly

Check List

1. In accordance with the “The control of legionella bacteria in water systems. Approved Code of Practice and guidance” (L8) - 2000, (see Appendix I) if there is a reasonable foreseeable risk of exposure to legionella bacteria then water tank temperatures need to be taken by competently trained personnel, recorded in a logbook and kept for 5 years.
2. Both mains temperature at ball valve and a temperature remote from ball valve to be taken. Temperature should be below 20°C
3. Fill Out Log Book
4. Inform Supervisor of any Anomalies.
5. Do not stand on internal stays while maintenance is being carried out.

Tank Maintenance & Inspection Interval: Annually

Check List

1. In accordance with the “The control of legionella bacteria in water systems. Approved Code of Practice and guidance” (L8) - 2000, (see Appendix I) if there is a reasonable foreseeable risk of exposure to legionella bacteria then water tank temperatures need to be taken by competently trained personnel, recorded in a logbook and kept for 5 years.
2. Do not stand on internal stays while maintenance is being carried out.
3. All internal supports should be checked for corrosion, if corrosion is found it should be rectified immediately.
4. Check generally for leaks or drips.
5. Check that all pipe work connected to the tank is suitably braced.
6. Check that the structural supports under the tank are in good condition.
7. When cleaning the inside of the tank, do not interfere with the joint seals.
8. Check that an overflow is fitted. If overflow and/or air inlet screens are fitted, check that they have not become blocked.
9. If insulated check that insulation and the manhole is securely fixed and not damaged, if they are damaged then the tank is not in compliance with Byelaw 30.
10. If not insulated in accordance with Byelaw 30, ensure that people cannot consume water from the tank. We can advise on upgrading the tank to Byelaw 30 standard.
11. If there is a Condensation Tray with the tank, ensure that it has an overflow fitted and that it has not been damaged.
12. If there are ladders fitted to the tank, ensure that they have not been damaged and are securely fastened to the tank.
13. If the tank has a light duty cover and sited out of doors, check that the cover has not suffered structural damage. (This type of cover is not suitable for potable water, outdoor use or for the storage of water for use in buildings).
14. If the area underneath / adjacent to the tank has become water sensitive check that the tank room is bunded with adequate escape ducts.
15. If the tank room is bunded, check that it is in good condition.
16. With tanks for drinking water, check that the water surface is clean and shiny and that the water doesn't contain any debris or contamination.
17. Check for evidence of stagnation of the water.
18. Check for excessive build up of sediment.
19. Check for presence of algae, biofilm.
20. Check for scaling on the tank sidewalls.

21. The cold water storage tank should be cleaned, disinfected and faults rectified, if considered necessary.
22. After maintenance of the tank is complete, ensure that the manhole seal is in tact and the manhole is securely closed.
23. Fill Out Log Book.
24. Inform Supervisor of any Anomalies.

Maintenance on Tanks with Dividers

Extra care should be taken during the maintenance of tanks with divisions, as maintenance staff will be working in an enclosed space, adjacent to a large volume of water in relation to the size of the space. (See Health & Safety Act)

Notes:

- Further information on the Health & Safety aspect, reference water quality is available in BS 6700 : 2006.
- Legal. (L8)(L 8) supersedes earlier editions and guidance published with ISBNs 0118821504, 0717604519, 0717607321 (HSG70)(HSG 70)(HS G 70) entitled, 'The control of legionellosis including Legionnaires' disease'. It also replaces guidance note environmental health 48. (GNEH48)(GNEH 48)(GN EH48) (GN EH 48) ISBN 011883939X supplemented by MISC150 (MISC 150) entitled, 'The control of legionellosis in hot and cold water systems.'

Appendix I

This approved code of practice and guidance gives practical advice on the requirements of the Health and Safety at Work etc Act 1974, and the Control of Substances Hazardous to Health 1999, concerning the risk from exposure to legionella bacteria. The Code also gives guidance on compliance with the relevant parts of the Management of Health and Safety at Work Regulations 1999. Contents: Notice of approval; Acknowledgements; Introduction; Part 1: The approved code of practice; Scope and application; Identification and assessment of the risk; Managing the risk: management responsibilities, training and competence; Preventing or controlling the risk from exposure to legionella bacteria; Record keeping; Responsibilities of manufacturers, importers, suppliers and installers; Part 2: Guidance on the control of legionella in water systems; Cooling systems; Management of cooling towers; Treatment program's; Monitoring; Cleaning and disinfection; Hot and cold water services; Design and construction; Management of hot and cold water systems; Treatment and control program's; General monitoring; Cleaning and disinfection; Other risk systems; Protection of personnel; Appendix 1 Recommended inspection frequencies for risk systems; Appendix 2 Action in the event of an outbreak; Glossary; References and further reading.

Disclaimer of liability

The material and information contained herein is for general information purposes only. You should not rely upon the material or information as a basis for making any business, legal or any other decisions. Whilst we endeavour to keep the information up to date and correct, Killarney Plastics makes no representations or warranties of any kind, express or implied about the completeness, accuracy, reliability, suitability or availability with respect to the information, products or services contained herein for any purpose. Any reliance you place on such material is therefore strictly at your own risk.

Do not stand on internal stays while maintenance is being carried out.

Glossary Of Terms

Sectional Tank : Rectangular fixed container assembled from panels for the storage of water at atmospheric pressure and at a maximum temperature of 30 °C.

Note : This temperature is higher than is acceptable for drinking water, which should not normally exceed 20 °C.

Nominal Capacity : Volume contained in a tank, measured up to the top edge of the side walls.

Actual Capacity : Volume contained in the tank up to the maximum working level, this can be between 10 and 50% less than the Nominal Capacity.

Bund Wall : Structure situated underneath water tanks. It's purpose is to protect the building from water damage. All water tanks located above areas that are water sensitive should be banded.

Ball Valve Housing : Enclosed chamber containing an access hatch above the level of the cover, permitting the level control mechanism to be mounted at a higher level than would otherwise be possible.

Vent : Opening to the atmosphere to allow for the movement of air resulting from changes in the water level so that the water always remains at atmospheric pressure.

Warning Pipe : Pipe so fixed that it's outlet, whether inside or outside a building, is in a conspicuous position where the discharge of water can be readily seen.

Overflow Pipe : Pipe connected to the tank to discharge any overflow therefrom.

Division Plate : Construction of one or more panels within a tank which divides the tank into two separate compartments.

Note : In any situation where there is only one water storage tank in a building, it is to be recommend that a weir or a division plate be used. This will facilitate maintenance of the tank without effecting the water supply to the building.

Weir : Construction of one or more panels within a tank, which divides the tank but to less than its full depth such that the contents can spill over from one side of the weir to the other.

Baffle : Construction of one or more panels within a tank, which partially subdivides the tank in order to increase the length of the flowpath between the inlet and the outlet from the tank.

Leakage Test : The duration of the test should be a minimum of 24 hours, commencing at least 2 hours after the tank has been filled. The test shall be carried out within 10 days of erection unless the manufacturer agrees to a longer period after assembly. The tank should be inspected at regular intervals and not deserted during commissioning (first filling with water). The leakage test is not carried out by Killarney Plastics .

BS 7491 : Part 3 : 1994 : Glass fibre reinforced plastics cisterns for cold water storage. Part 3 Specification for sectional tanks.

BS 6700 : 1997 : Specification for design, installation, testing and maintenance of services supplying water for domestic use within building and their curtilages.

STANDARD CONTRACT CONDITIONS

1. FORM OF CONTRACT

- (a) All orders and acceptances thereof and all variations or modifications of such orders and acceptances shall be in writing by prepaid letter only and shall be deemed to incorporate these conditions so far as the same are applicable.
- (b) All illustrations, drawings, specifications of weight, capacity and consumption data or other documents supporting or forming part of any Quotation (hereinafter called "additional documents") shall be considered approximate unless expressly otherwise stated therein. All such additional documents shall remain the property of Killarney Plastics (hereinafter referred to as "the Company"). The copyright in all such additional documents shall be and remain in the Company. No such additional documents or the contents thereof shall be disclosed or made available to any other person, firm or corporation without the prior consent of the Company in writing.

2. PRICE AND PAYMENT

- (a) Unless otherwise stipulated the purchase price or the subject matter the contract (hereinafter referred to as "the goods") shall be ex-factory but shall include the cost of transport, erection, installation and commissioning.
- (b) Payments shall be effected in cash on the due date for payment without deduction at the place and in the manner designated by the Company.
- (c) In the event of default in payment, the Company shall be entitled without notice to the Purchaser to charge and receive interest on the purchase price at the rate of 3% per annum above the bank rate for the time being in force.
- (d) In the event of any variation in the price of materials or wages, the Company shall be entitled to adjust the purchase price of the goods accordingly.

3. PASSING OF PROPERTY

- (a) The ownership and the property in the goods shall remain in the Company until all monies due under the Contract have been paid to the Company.
- (b) Until the property and ownership in the goods has passed to the Purchaser as aforesaid, the Company shall be entitled to insure the goods in the Company's name and at the expense of the Purchaser.
- (c) Until the ownership and the property in the goods has passed to the Purchaser, the Purchaser shall not sell, let on hire, mortgage, charge, pledge, transfer as security or part with possession of the goods or purport to do so.
- (d) Until the property and the goods has passed to the Purchaser as aforesaid, the Purchaser shall keep the goods in good and marketable condition and shall, except in case of emergency, procure that all repairs or replacements which may be required to the goods shall be effected by the Company or its duly appointed Agents at the cost of the Purchaser.

4. TIME OF DELIVERY

- (a) Delivery of the goods shall be considered to have been effected if the Company has been given notice that the goods are ready for delivery to or in accordance with the instructions of the Purchaser.
- (b) Dates quoted for commencement and completion of manufacture and delivery shall be approximate. On no account shall the Company be liable for any delay in delivery of the goods caused through delay in delivery to it of raw materials, components, or things required in the construction of the goods, strikes, lock outs, acts of God, force majeure, governmental action or other circumstances over which it has no control.

5. TRANSFER OF RISK

The goods shall be at the Purchaser's risk as and from delivery.

6. ERECTION

The Company shall where necessary or appropriate erect or install the goods at the Purchaser's works. The Purchaser, shall free of cost to the Company, whether or not a fixed sum has been agreed for erection or assembly, lay such foundations as may be specified by the Company (including concrete base or supports) and provide at the Purchaser's expense, electric light and power, scaffolding, and any other matters required by the Company to erect or install the goods

7. LIABILITY FOR DEFECTS.

The Company shall not be liable for any defects in the goods or unfitness for use which the Purchaser has made known to the Company except and to the extent that the company shall repair or replace free of cost (if the Company shall decide) any part or parts of the goods which are defective or become unserviceable due to fault in design, installation, inferior materials, or fault in manufacture within three months from the date on which same were delivered to the Purchaser. Any such fault to be reported to the Company in writing forthwith.

8. Except as and to the extent expressly stipulated herein, the Company shall be exempt from all liability hereunder for direct or consequential damages howsoever arising. The Purchaser agrees to indemnify the company in respect of the entirety of any claim brought by any third party against the company howsoever arising from or in relation to the goods, or in relation to the Purchaser's use of the goods.

9. The purchaser warrants and undertakes that it shall use the goods strictly in accordance with the specifications of weight and/or capacity and/or use supplied by the company and that it shall not exceed, deviate from, or use in any manner howsoever in contravention of same. If the Purchaser's use exceeds, deviates from, or any manner howsoever contravenes the specifications, the company shall be exempt from all liability howsoever arising for direct or consequential damages, and the Purchaser agrees to indemnify the company in respect of any claim brought by any third party arising from the Purchaser's such use.

10. ASSIGNMENT OF CONTRACT

The Purchaser shall not without the prior consent of the Company in writing assign or transfer or purport to assign or transfer the Contract to any third party whatsoever.

11. SPECIAL CONDITIONS IN RELATION TO ERECTION OF TANKS

The Purchaser's order is confirmed on the basis of the following representations made by the Purchaser to the Company.

- (a) That reasonable site conditions are available
- (b) That there is a minimum of 460 mm (18 inches) working space all round the tank.
- (c) That all components will be available at the point of installation (for example where necessary, the components will be lifted by the purchaser to the roof of a building, should the tank be located on the roof).

12. HEALTH AND SAFETY AT WORK.

The company gives notice to the Customer that information and product literature is available concerning the conditions necessary to ensure that the Goods supplied against the contract will be safe and without risk to the health when used, handled, processed, stored or transported by a person at work. The customer should immediately contact the Company if he is not in possession of such information or literature. The Company also gives notice that the goods are sold in containers which may have any necessary hazard information as part of the container identification label. The Customer undertakes to comply with any stated conditions for the prevention of Health and Safety Hazards.

13. This Contract shall be construed and governed in all respects by the laws of the Republic of Ireland. The Purchaser and the company agree to submit to the exclusive jurisdiction of the Courts of the Republic of Ireland.

SAMPLE TANK LOG BOOK

Date of Tank Inspection: _____

Inspection Carried out By: _____

All Maintenance Items Check Yes No

Action Taken on Tank: _____

Action Required: _____

Comments: _____

Print Name

Signed

Date of Tank Inspection: _____

Inspection Carried out By: _____

All Maintenance Items Check Yes No

Action Taken on Tank: _____

Action Required: _____

Comments: _____

Print Name

Signed

SAMPLE TANK LOG BOOK

Date of Tank Inspection: _____

Inspection Carried out By: _____

All Maintenance Items Check Yes No

Action Taken on Tank: _____

Action Required: _____

Comments: _____

Print Name

Signed

Date of Tank Inspection: _____

Inspection Carried out By: _____

All Maintenance Items Check Yes No

Action Taken on Tank: _____

Action Required: _____

Comments: _____

Print Name

Signed